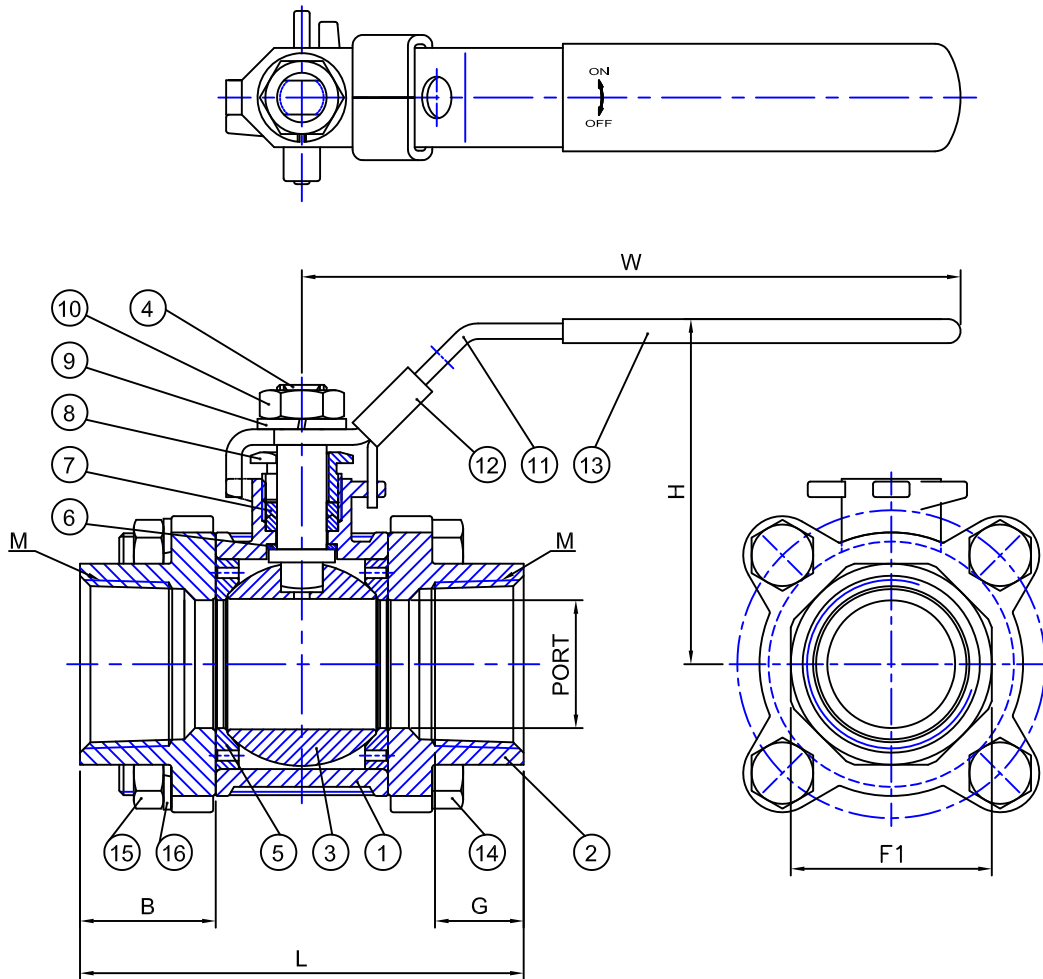

Fig No:

PB-3110C

MATERIAL LIST

NO.	PART NAME	MATERIAL		Q'TY
		STAINLESS STEEL	CARBON STEEL	
1	BODY	A351-CF8M	A216-WCB	1
2	CAP	A351-CF8M	A216-WCB	2
3	BALL	A351-CF8M		1
4	STEM	SS316		1
5	SEAT	RPTFE		2
6	THRUST WASHER	PTFE		1
7	STEM PACKING	PTFE		1SET
8	GLAND NUT	SS304		1
9	SPRING WASHER (1)	SS304		1
10	NUT (1)	SS304		1
11	HANDLE	SS304		1
12	LOCKING PAD	SS304		1
13	HANDLE COVER	PLASTIC		1
14	BOLT	SS304		4
15	NUT (2)	SS304		4
16	SPRING WASHER (2)	SS304		4



DIMENSIONS

SIZE	PORT	F1	B	G	L	H	W	M	CV	Torque (kgf-cm)	Weight (kgs)
1/4"	12.55	20.5	18.2	15	55	43.4	82	NPT	24	45.88	0.45
3/8"	12.55	20.5	18.2	15	55	43.4	82	NPT	24	45.88	0.45
1/2"	15	25	21	17	65	47.9	82	NPT	37	71.37	0.56
3/4"	20	31.5	23.5	17	74.6	57.2	102	NPT	68	101.96	0.70
1"	25	38.5	26	17	85	67.3	127	NPT	109	132.55	1.04
1-1/4"	32	47	29.2	21	99.6	72.7	127	NPT	185	173.34	1.66
1-1/2"	38	54	30	21.5	109.5	84.5	162	NPT	268	224.32	2.44
2"	50	65.5	32.6	24	129	92.5	162	NPT	486	305.89	3.75

Pressure VS. Temperature Chart

